



**We are the
Difference.**

SINGLEFOLD



- lightweight, easy to handle and set up.
- folds in half, carries like a suitcase.
- durable welded fabrication.
- full platform provides excellent stability.
- anti-slip, high traction surface.
- accommodates wheelchairs and scooters with various wheel configurations, safety video and steel security pins included.



Prairie View Industries, Inc.

prairie view industries, inc. | ramp division | p.o. box 575 | fairbury, ne 68352-0575
phone 800-554-7267 | fax 402-729-4058 | email info@pviramps.com | www.pviramps.com



Prairie view industries, inc.
RAMPS

access ramps

SINGLEFOLD

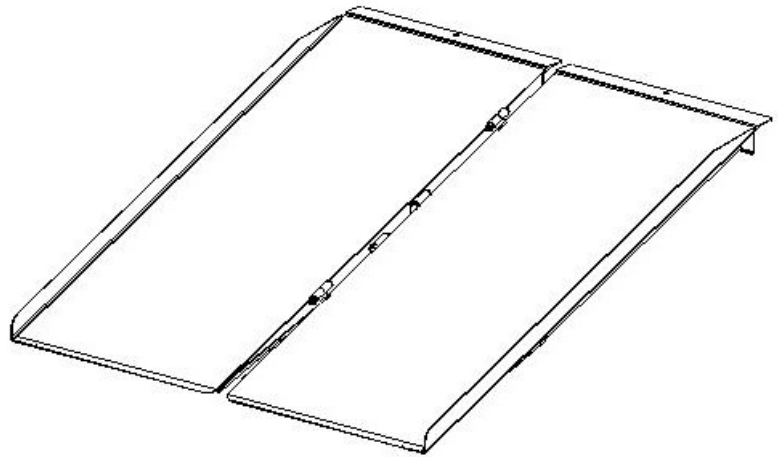

FEATURES

- lightweight, easy to handle and set up.
- folds in half, carries like a suitcase.
- durable welded fabrication.
- full platform provides excellent stability.
- anti-slip, high traction surface.
- accommodates wheelchairs and scooters with various wheel configurations, safety video and steel security pins included.

DETAILS AND SPECIFICATIONS

- safety video and steel security pins included.
- maximum ramp capacity: 300 lbs. one axle - 600 lbs. two axles.
- listed by Underwriters Laboratories, Inc.

SINGLE FOLD					
Item Number	Length (feet)	Width (inches)	Folded Size (inches)	Weight (lbs.)	Capacity* (lbs.)
SFW230	2	30	24 X 16 X 4 7/8	10	600
SFW330	3	30	36 X 16 X 4 7/8	15	600
SFW430	4	30	48 X 16 X 4 7/8	20	600
SFW530	5	30	60 X 16 X 4 7/8	24	600
* Maximum ramp capacity: 300 lbs. one axle - 600 lbs. two axles.					
Custom Widths Are Available.					

Item #:

Model #:

Project #:

Quantity #: